

TECHNICAL DATA WASTE RECEPTACLE WALL MOUNTED

MODEL S-150

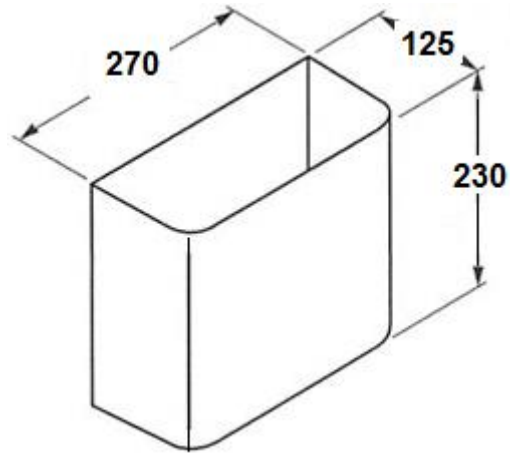

Size: (WHD) 270mm x 230mm x 125mm

Material: Type 304 - 0.7mm stainless steel with a satin finish

Capacity: 7.5 litres

Installation:

Secures to the wall with mounting screws using the holes provided



Phone: (02) 95344031

Fax: (02) 95841030

www.starwashroom.com.au

Email: info@starwashroom.com.au

ABN: 78 146 670 493 | ACN: 146 670 493

Unit 2 , 41-45 Lorraine St , Peakhurst NSW 2210
P O Box 2210 , Peakhurst NSW 2210