



# 'Benefit' Basin | Wall Mounted

## Models RBA8867-100, RBA8867-186



### Materials & Features

Manufactured from stainless steel with all exposed surfaces in satin finish. Trap is fully enclosed for security and aesthetics.

### Technical Detail

Basin and Housing:	1.2mm, type 304 Stainless Steel
Tap Hole:	35mm
Trap:	40mm Iplex low level 'P' trap (by others)
Outlet Connection:	40mm BSP waste
Tap:	6 star WELS, Satin Stainless Steel Timed Flow
Tap Inlet:	G½B

### Available Models

- RBA8867-100** Wall Mounted 'Benefit' Basin
- RBA8867-186** Wall Mounted 'Benefit' Basin including compliant Tapware

### Related Products

- RBA4150-101** Accessible Compliant Backrest
- RBA8847-428** Accessible Compliant Stainless Steel Toilet Suite with Seat
- RBA8900-429** Accessible Compliant Wall Mounted Drinking Fountain

**Important:** Installation instructions and current rough-in details should be furnished with each fixture. Do not rough in without certified dimensions. Dimensions are subject to manufacturer's tolerance of +/-10mm.

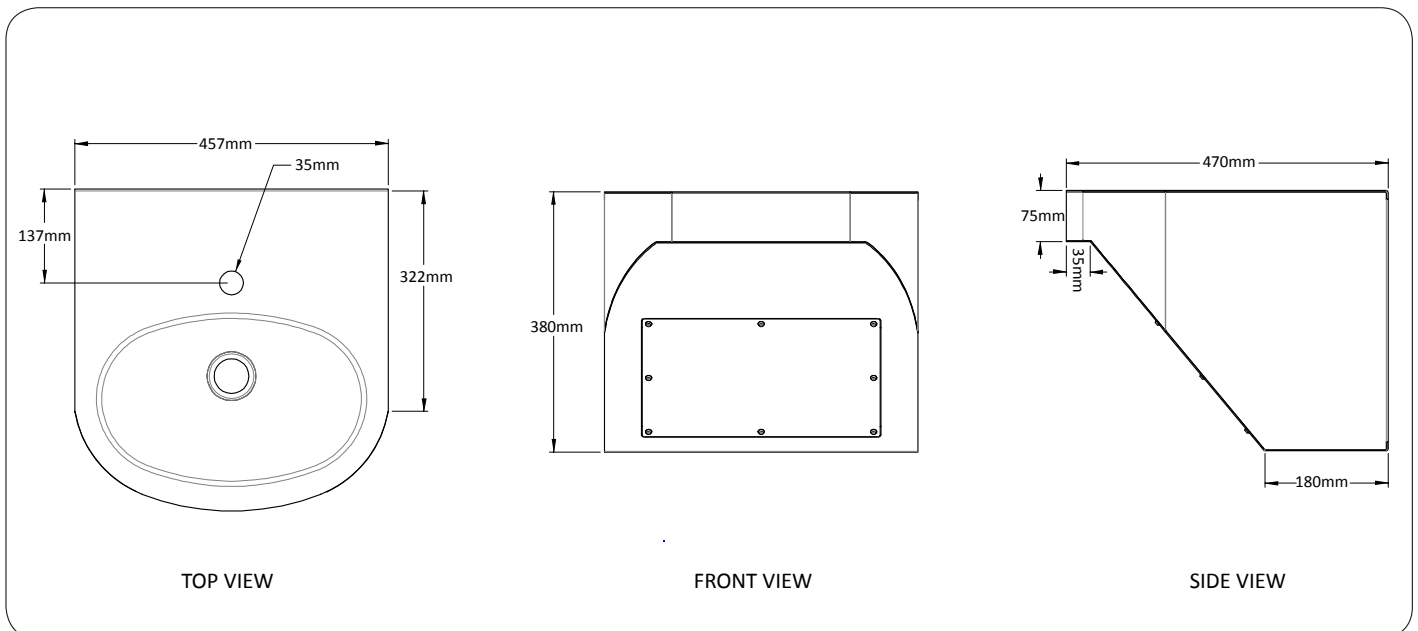

As improvements in the design and performance of RBA products are continuous, specifications may be subject to change without notice. The illustrations and descriptions herein are applicable to production as of the date of this Technical Data Sheet. Revised 04/15 © 2015 by RBA Group TD/Model RBA8867-100/0415