



# Accessible Wall Mounted Drinking Fountain

Model RBA8900-429



## Materials & Features

Accessible Compliant to AS1428.2-1992. Manufactured from stainless steel with all exposed surfaces in satin finish. Stainless steel, shielded bubbler with self-closing, luminance contrast, push button and non-squirt features. Valve includes flow adjuster and strainer. Integral splashback and perforated drain for hygiene & ease of cleaning. Smooth radiused design eliminates sharp corners. Unit is non-refrigerated.

## Technical Detail

Inlet Connection:	G $\frac{1}{2}$ B
Outlet Connection:	40mm BSP waste
Water Pressure:	200 – 500 kPa
Water Temperature:	4 - 30°C
Basin and Housing:	1.6mm, type 304 Stainless Steel
Force to Activate:	< 20N

## Installation

Ensure wall construction is suitable to support the unit mount to wall. Trap and wall anchors by others. Typical mounting heights may be 700mm to bench to comply with AS1428.2-1992. Other mounting heights of 895mm (e.g. SOPA) may be recommended. Consult local codes and building authorities for recommended heights.

## Related Products

- RBA8901-102** Drinking Fountain, enclosed trap
- RBA2730-032** Compact Wall Mount Water Cooler
- RBA2750-031** Remote Chiller

**Important:** Installation instructions and current rough-in details should be furnished with each fixture. Do not rough in without certified dimensions. Dimensions are subject to manufacturer's tolerance of +/-10mm.

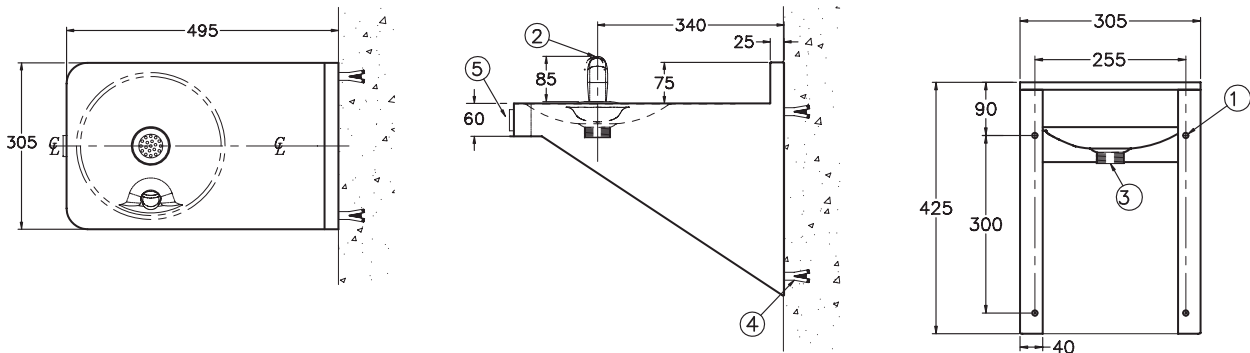

- ① 10mm Diameter Anchoring Holes
- ② Drinking Bubbler
- ③ 40mm BSP Waste Connection
- ④ Installer Provided Wall Anchors And Anchoring Hardware
- ⑤ Pushbutton/Valve Assembly



As improvements in the design and performance of RBA products are continuous, specifications may be subject to change without notice. The illustrations and descriptions herein are applicable to production as of the date of this Technical Data Sheet. Revised 01/15 © 2015 by RBA Group TD/Model RBA8900-429/0115