

RBA4L50 Basin Mixer



APPLICATION

Suitable for use with basins or benchtops up to 50mm thickness. Supplied with 350mm exible 15mm BSP tails for easy installation.

TAP HOLE

Tap hole diameter between 32-35mm.
Horseshoe washer and pin bolt for easy installation.

FEATURES

- Softclose™ ceramic cartridge prevents water hammer.
- Water supply pressure 50-1000kPa.
- Recommended operating pressure 100-500kPa.
- Adjustable flow control.
- Adjustable hot water limitation.
- Low noise filters.
- 10 year warranty on cartridge.
- Made in Sweden.

OPTIONS

Refer to Optional Items and Accessories for Details.

COLOURS

Chrome

APPROVALS AS3718

Manufactured in DR brass
AS/NZS 6400 (WELS)

MODELS

RBA4L50-7070

RBA4L50 Basin Mixer

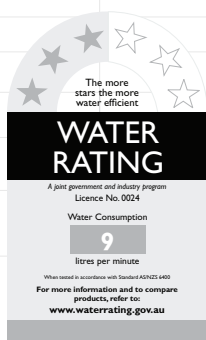
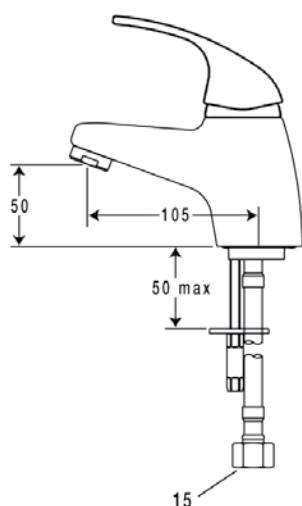

FM Mattsson

— Different on the inside

Technical Specifications

SYDNEY • MELBOURNE • BRISBANE • PERTH • AUCKLAND
Australia 1300 788 778 • sales@rba.com.au • www.rba.com.au
New Zealand 0800 722 111 • sales@rbagroup.co.nz • www.rbagroup.co.nz

