

AMBULANT TOILET S-TRAP



RBA8851-156 Amubulant Toilet S-Trap

Materials & Features

Wall faced WC Pan is manufactured from heavy-gauge (1.9mm trap & bowl 1.5mm housing), type 304 stainless steel. External surface is satin finish. Internal surface is a unique matt satin ultra-smooth finish that is hygienic, easy to clean and resistant to scale build-up. The integral seat is bright polished for hygiene and comfort. Pre drilled and capped holes for additional plastic seat if required.

Trap: Seamless one-piece smooth bore trap with radiused bends. Formed with a minimum 50mm deep water seal.

Outlet: 100mm overall S-Trap outlet suitable for a standard pan collar.

Inlet: Back inlet, 55mm internal diameter water inlet socket, to accept standard kee seal.

Fixings: By others. To order tool to suit security screws on access panel, quote model # A111-99.

Optional extras:

RBA8186-100 Hinged white seat with lid

RBA8186-102 Hinged white seat no lid

Performance Standards

Unit has WATERMARK & WELS certification and meets the ambulant requirements of AS1428.1-2009 (Amdt 1-2010) where installed correctly. Unit is 460mm high when installed with optional seat (order separately), alternatively for secure installations with no hinged seat contact RBA.

Installation

Ensure wall construction is suitable to support the unit. Anchors for wall-mounting to be supplied by others. Suitable for installing with a concealed duct mounted cistern or flush valve. Refer Installation Instruction for location of fixing points, trap outlet location, etc.

Important: Installation instructions and current rough-in details should be furnished with each fixture. Do not rough in without certified dimensions. Dimensions are subject to manufacturer's tolerance of +/-10mm.

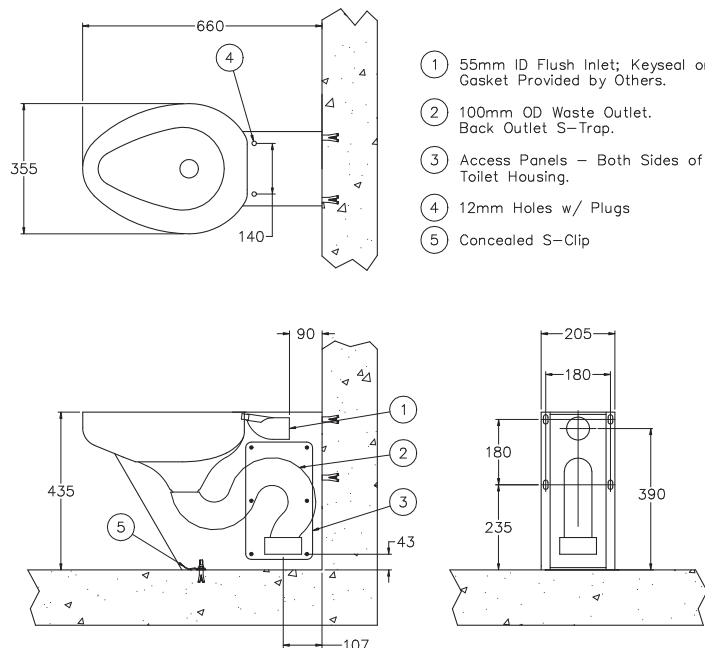

As improvements in the design and performance of RBA products are continuous, specifications may be subject to change without notice.

The illustrations and descriptions herein are applicable to production as of the date of this Technical Data Sheet.

Revised 06/13

© 2013 by RBA Group

TD/Model RBA8851-156/0613

SYDNEY • MELBOURNE • BRISBANE • PERTH • AUCKLAND

Australia 1300 788 778 • sales@rba.com.au • www.rba.com.au

New Zealand 0800 722 111 • sales@rbagroup.co.nz • www.rbagroup.co.nz