

**TECHNICAL DATA**  
**SLIM LINE PAPER TOWEL DISPENSER**  
**SURFACE MOUNTED WHITE**

**MODEL S-126-8**

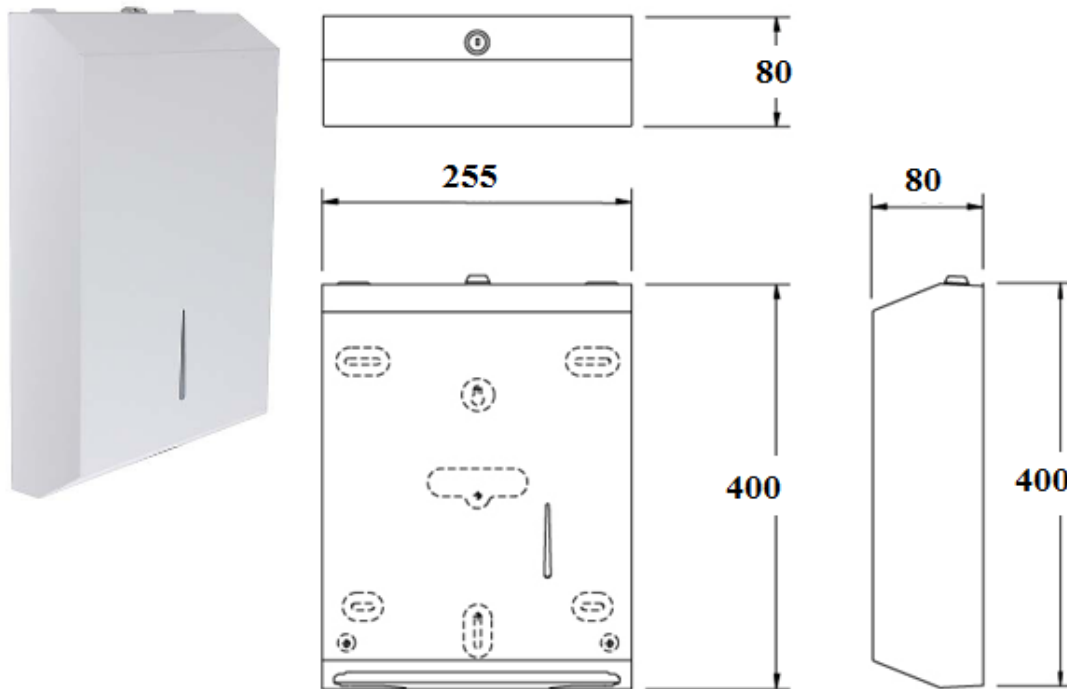

**Size:** (WHD) 255x 400x80mm

**Material:** Zinc coated steel with a white powder coated finish

**Construction:**

Fabricated from - 0.7mm zinc coated steel

The unit is locked with a tumbler lock and the hinge is on the bottom at the back

Refill indicator slot on face of cabinet

**Capacity:**

3 packs of slim line interleaved fold paper towels

**Installation:**

Secure to wall with mounting screws at holes provided



Phone: (02) 95344031

Fax: (02) 95841030

[www.starwashroom.com.au](http://www.starwashroom.com.au)

Email: [info@starwashroom.com.au](mailto:info@starwashroom.com.au)

ABN: 78 146 670 493 | ACN: 146 670 493

Unit 2 , 41-45 Lorraine St , Peakhurst NSW 2210

P O Box 2210 , Peakhurst NSW 2210