

**TECHNICAL DATA**  
**Horizontal Liquid Soap Dispenser**  
**Recessed Mounted**

**MODEL S-480**

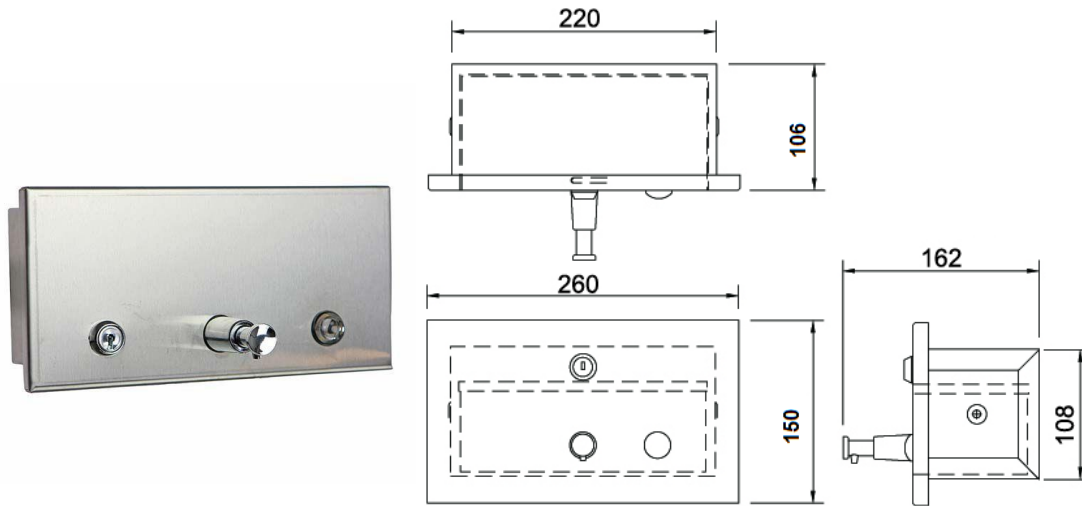

**Size:**

(WHD) 260mm x 150mm x 162mm (including the valve)

**Wall Opening:**

(WHD) 220mm x 108mm x 106mm

**Construction:**

**Housing** - Type 304 0.7mm stainless steel with a satin finish

**Face plate** - Type 304 1.2mm stainless steel with a satin finish

**Soap Valve** – chrome plated brass housing with an ABS plastic mechanism

The face plate is hinged to the body and locks with a tumbler lock

**Capacity:** 1200 ml

**Operation:**

The push-in valve dispenses a measured amount of liquid soap

Locked filler top opens with the special key provided

Sight gauge indicates low soap level

**Installation:**

Secure the unit to the wall using the screws provided



Phone: (02) 95344031

Fax: (02) 95841030

[www.starwashroom.com.au](http://www.starwashroom.com.au)

Email: [info@starwashroom.com.au](mailto:info@starwashroom.com.au)

ABN: 78 146 670 493 | ACN: 146 670 493

Unit 2 , 41-45 Lorraine St , Peakhurst NSW 2210

P O Box 2210 , Peakhurst NSW 2210