

TECHNICAL DATA TOWEL SHELF WITH TOWEL BAR

MODEL S-510

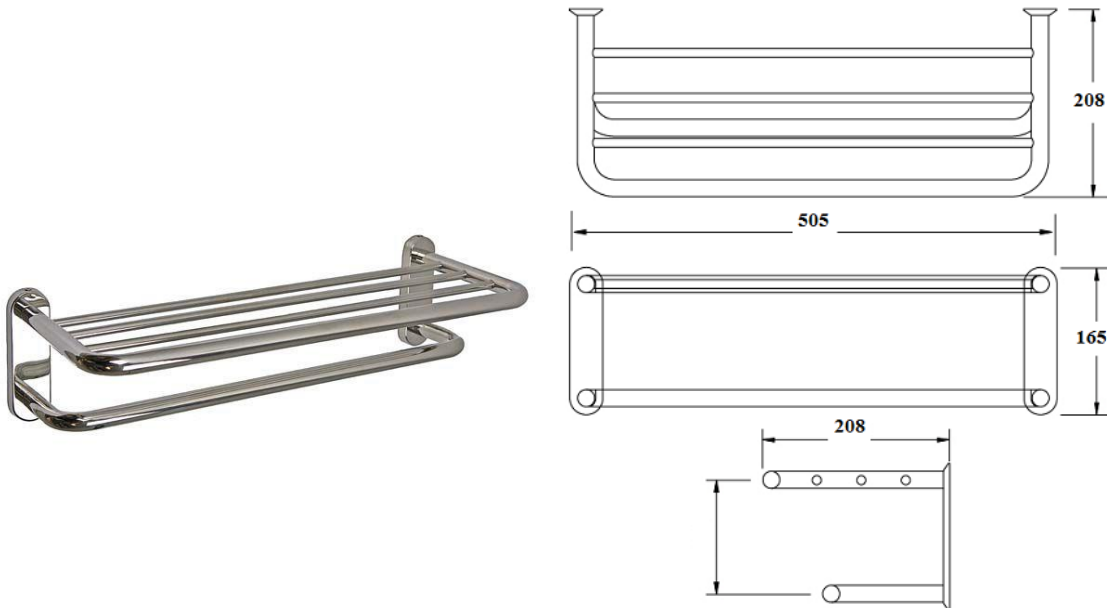

Size:
(WHD) 505mm x 165mm x 208mm

Material:
The main rail is fabricated from 19mm diameter type 304 - 0.7mm bright polished stainless steel
The insert rails are 10mm diameter type 304 - 0.7mm bright polished stainless steel
The hidden internal mounting bracket is fabricated from 1.2mm galvanized steel

Installation:
Secure the concealed wall mounting bracket to the wall with mounting screws using the holes provided
Mount the top and bottom rail to the escutcheons with the screws provided
Fit the escutcheons onto the mounting bracket and lock with the screws on the top and bottom



Phone: (02) 95344031
Fax: (02) 95841030
www.starwashroom.com.au
Email: info@starwashroom.com.au
ABN: 78 146 670 493 | ACN: 146 670 493
Unit 2 , 41-45 Lorraine St , Peakhurst NSW 2210
P O Box 2210 , Peakhurst NSW 2210